

NO	QTY	DESCRIPTION	MODEL NUMBER		STANDARD SEAL KIT
			L1-4132-00-X-US	L1-4150-00-X-US	
1	1	NUT, JAM, HEX	21-5100-04	21-5100-05	
2	3	SPRING, COMPRESSION	23-3500-87	23-3500-87	X
3	3	BALL, TUNGSTEN-CARBIDE	23-6500-11	23-6500-11	X
4	2	O-RING, PLUG SEAL	39-0510-80	39-0510-80	X
5	1	O-RING, CAP SEAL	39-0510-85	39-0510-86	X
6	2	O-RING, MANIFOLD SEAL	39-0510-88	39-0510-88	X
7	1	SEAL, WIPER, SNAP IN	39-0530-46	39-0530-47	X
8	1	SEAL, STEP, ROD	39-0560-06	39-0560-07	X
9	1	SEAL, CAP, PISTON	39-0560-25	39-0560-26	X
10	2	PLUG, SOCH	43-0680-06	43-0680-06	
11	1	PLUNGER, LEFT HAND (SHOWN)	81-4001-35	81-4001-36	
	1	PLUNGER, RIGHT HAND	81-4001-45	81-4001-46	
	1	PLUNGER, STRAIGHT	81-4001-22	81-4001-24	
12	1	CAP, LC/SC, 7MPa	81-4001-55	81-4001-56	
13	2	PLUG, MANIFOLD, 7MPa	81-4002-01	81-4002-01	
14	3	PIN, STOP ,BALL, METRIC	81-4002-04	81-4002-04	X
15	1	SENSOR, ULTRASONIC, M12, 1m	29-7402-00	29-7402-00	
16	1	SENSOR, FACE SEAL	43-000040	43-000040	
N/A	N/A	SEAL KIT (STANDARD)	L6-0146-30	L6-0148-00	NOTED

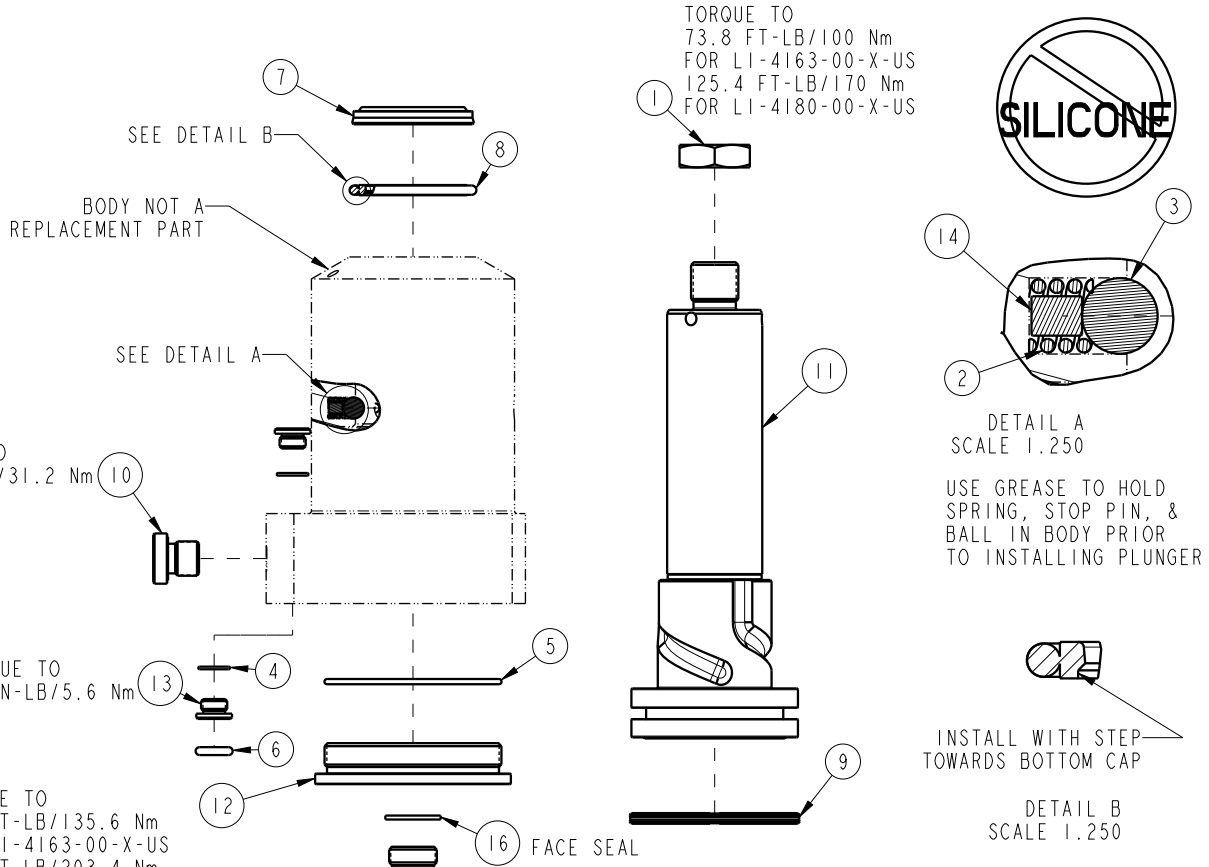

PARTS LIST		
	VEKTEK, INC. 1334 E. SIXTH AVE. P.O. BOX 625 EMPORIA, KS. 66801 U.S.A.	
ASSEMBLIES AFFECTED	PARTS LIST, SC, BF, 7MPa, 63B, 80B	
L1416300XUS L1418000XUS	SIZE A	LPL1465
	REV A	

A	5779	RELEASE	ALS	7/29/25
REV	IN ACCORDANCE WITH ECN	EFFECTIVE DATE	REVISED BY	DATE
DRW BY: ALS	DRAWING STATUS: Released			
DATE: 7/28/25	PRODUCTION APPROVED FOR RELEASED STATUS ONLY			